

SP-08.01 – FEBR. '08

MC 1210 AT 230/60/3

**NEW COPELAND
COMPRESSOR**

Starting from MC 1210 s.n. 3666 the previous Tecumseh Europe compressor operating at 230V 50-60Hz 3Ph has been replaced with a new Copeland one that operate **ONLY at 230V 60Hz 3Ph.**

The Part Nbr of this new compressor is 18008749 24 and it's exchangeable with the former one making some modification on the refrigerant tubes.

**SEMPRE
MEGLI
SERVIZIO
TECUMSEH**

SP-08.02 – FEBR. '08

MV SERIES

CHANGES IN PC BOARD SOFTWARE

Starting from end of 2007, the Software of the PC Board used in all MV units has been modified on the operation of the AUTORESET Jumper/Contacts.

Rather than move automatically the machine in Auto-Reset Mode, when the AUTORESET contacts are open (see photo below)

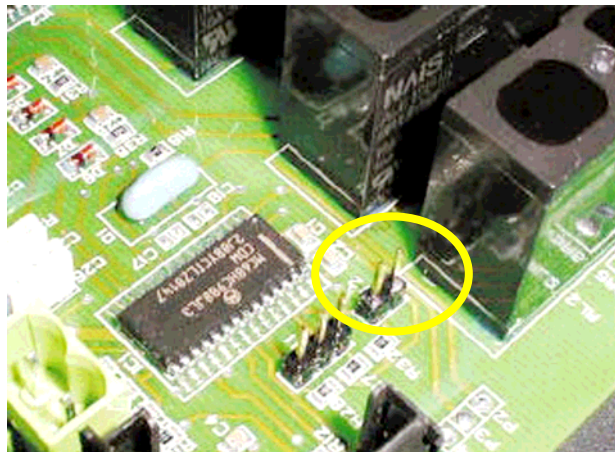

the new software is keeping a constant level of the water into the water reservoir during the entire freezing cycle by energizing the water inlet solenoid valve once the water level drops down from the two metal plates of the water level sensor.

This modification has been required for the machines installed on board of the vessels in order to assure water all the time into the water reservoir (at lower level compare with the standard machines) during the freezing cycle.

In case the MV PC Board Part Nbr CM 33580150 is installed in a standard machine W/OUT the Jumper on the Auto-Reset contacts, the machine is constantly asking for water during the freezing cycle.

If so, to solve the problem, just Jump IN the two contacts in Manual-Reset mode to have the water level sensor energizing the water inlet solenoid valve just at the beginning of the freezing cycle.

NEW
MACHINES

SP-08.03 – FEBR. ‘08

AC 46 - AC 56 - AC 86 - AC 106

**NEW MASTER AND
ALARM/RE-SET SWITCHES**

Starting from the following serial nbrs:

AC 46	S.N.	4743
AC 56		1860
AC 86		1968
AC 106		1552

the Green Master Lighted Switch as well as the Red Alarm/Re-Set Switch have been changed again going back to the original solution/application used on the AC..6 series manufactured till mid 2007.

The new Switches are available under the same part nbrs of the first ones i.e.:

Green Master Lighted Switch	P/N	620487 00
Red Alarm/Re-Set Switch		620487 01

These new Switches are a little bit different in size (19,6 mm wide, at plastic clips location, rather than 19,4 mm) of the former one as well as in their contacts/spade connectors identification numbers.

Attached the wiring diagram showing the electrical connections of the two Lighted Switches with the references of the electrical contacts of the old ones (inside the brackets) and new/current ones (with no brackets).

Anyway, as in the new switches the contact numbers are not very easily readable we suggest you to look all the time to the small pin (see on the circle of the bottom photo) anytime it's needed to replace it.

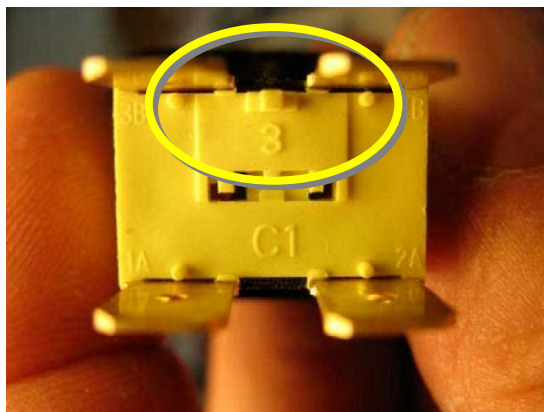

**NEW
SERIES**

The same are also shown on the drawings attached.

The Switches used on AC..6 Series manufactured from mid 2007 up to now, will be kept available as spare parts under the following part nbrs:

Green Master Lighted Switch	P/N	620487 02
Re-Set Switch		620487 03
Red Warning Light		620504 00

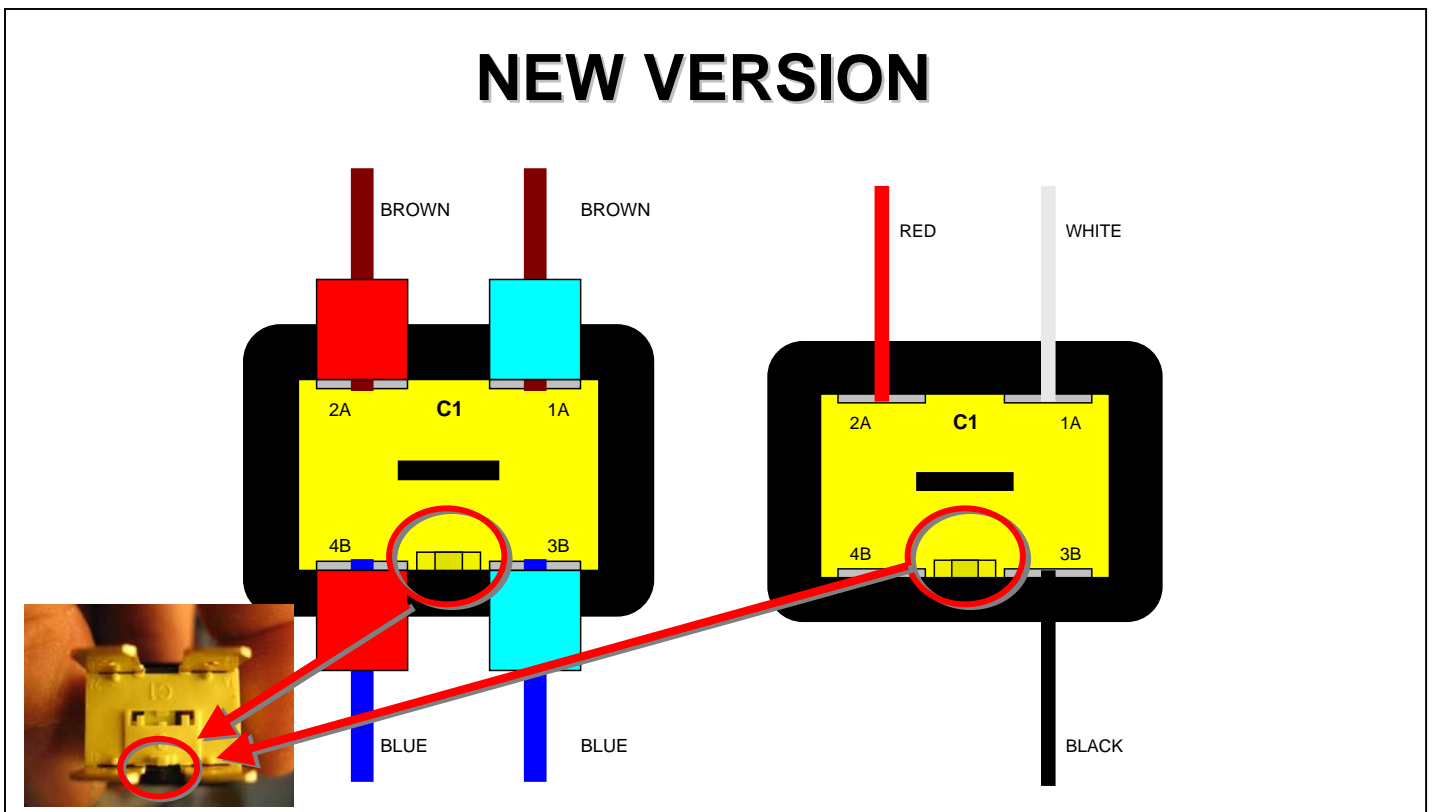
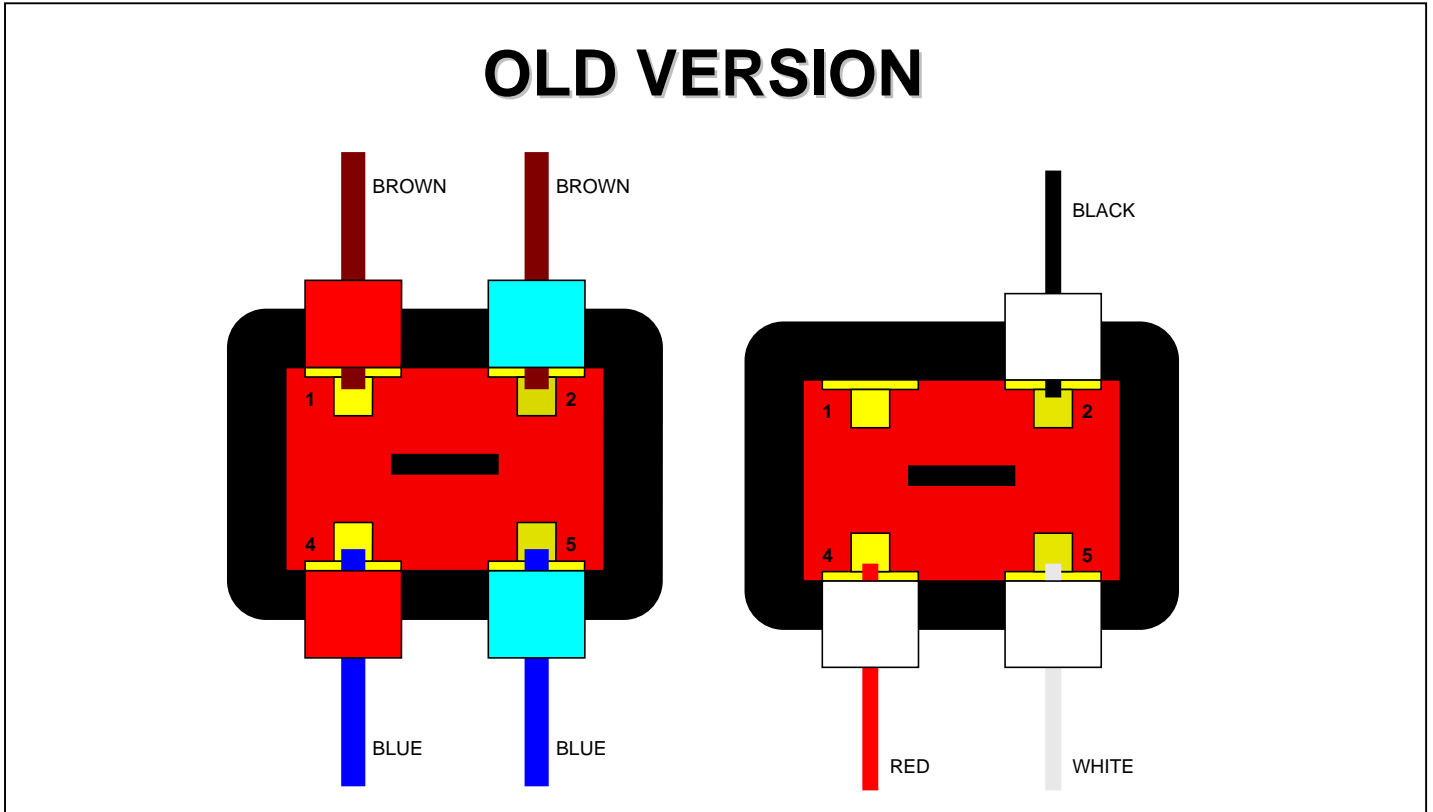

SP-08.04 – MARCH '08

TC 180

**NEW WATER TRAY DRAIN
FILTER**

Starting from last month we have changed the drain filter of the water drip tray moving from the standard one used in all storage bin to a version with a central hole for easy cleaning of the inside of the water drain/waste hoses as shown on the here below photo.



This drain filter with central hole is available under Part Nbr 660211 03 and can be used in place of the old one.

**NEW
MARCH
2008**

SP-08.05 – MARCH '08

ACC COMPRESSORS

NEW TERMINAL BOARD

Recently we have received from our compressor supplier ACC (former name Cubigel) compressors equipped with a new electrical control box.

To help you in its electrical connections, mainly when new compressor is used in place of a old version one, we are sending here below a photo showing the power connections so to avoid any possible confusion at time of installation.

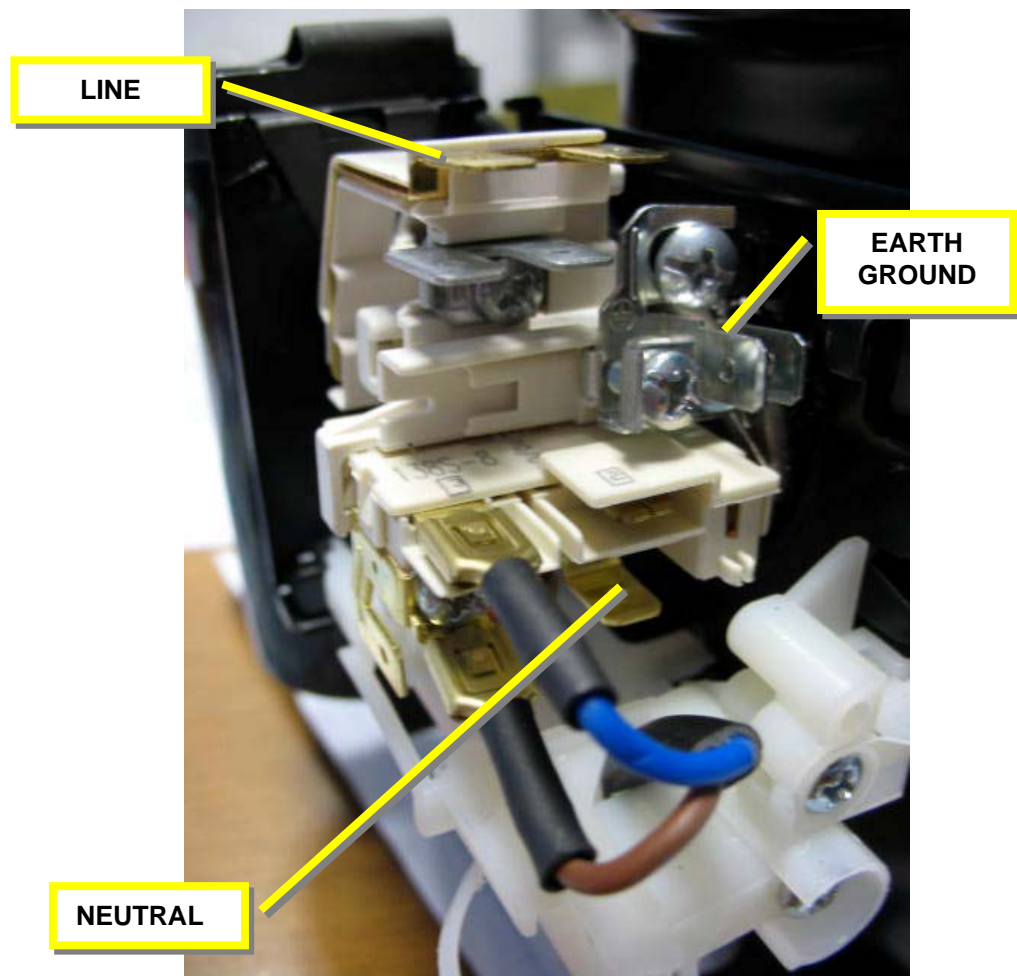

NEW
SERIES
FOR
ACC
COMPRESSORS

SP-08.06 – MARCH '08

AF/MF SERIES

COUPLING LUBRICATION

We would like to remind you that it's very important to provide correct/proper lubrication of the inside bore of the upper semi-coupling as well as to the external surfaces of the teeth as shown on the here below photo.

The correct lubrication allows the upper semi-coupling to move it down, by the load of the upper spring, in case of any rising up during its rotation.



SEMI-COUPLES

SP-08.07 – MARCH ‘08

MC 8 AS/WS

NEW MODEL

NEW ICE CUBERS SERVICE

A new Modular Cuber is now available for the market.

It's mainly based on the same refrigerant, water and electrical system of the model AC 206 but w/out the storage bin.

About PC Board, this new model is equipped with a new generation of PC Board, already tested in the field on more then one hundred machines.

This new PC Board, available under Part Nbr 620462 06 consists of the standard PC Board used till new with the integration of the Cleaning Reminder Board.

Moreover the compressor relay installed in this PC Board can load up to 16 amps current enabling the direct connection of the compressor to the PC Board.

Attached you can find the schematic diagram of this new PC Board of both our two PC Board suppliers (Syen & Pro.El.Ind.) where it's also possible to connect directly the water reservoir level sensor (Red Sensor Socket) of the machines equipped with water pump discharge system (EC Series).

Setting of the Dip Switches for Medium Size Cube is:

	1	2	3	4	5	6	7	8	9	10
MCM 8 A	ON	OFF	ON	ON	ON	OFF	ON	ON	ON	ON
MCM 8 W	ON	OFF	ON	ON	ON	OFF	ON	ON	ON	OFF

This new PC Board is no longer equipped with the I/R Trimmer as the calibration of the Optical Ice Level Control can be done directly with the PC Board as per here below procedure:

- Be sure that both Transmitter & Receiver of the Ice Level Control are properly clean and scale free
- Switch OFF the machine at Green Master Push Button Switch
- Push and Hold the PC Board Push Button
- Switch ON the machine at Green Master Push Button Switch
- Wait few seconds till the PC Board Leds flash once
- Release the PC Board Push Button
- Calibration is done

This operation can be done anytime is needed and **MUST** be done when a new PC Board or a new Optical Ice Level Control is installed/replaced in the machine.

This new PC Board is also set up to Switch **OFF** the machine at Bin Full **ONLY** at the end of the Harvest/Defrost cycle enabling the machine to discharge **ONLY** full size cubes and have the water system already filled up with water for new freezing cycle.

Attached please find the instruction for the removal of the Optical Ice Level Control (in case it's needed) from its inside transport location.

The MC 8 Service Manual will be available shortly in internet at our web site www.scotsman-ice.it

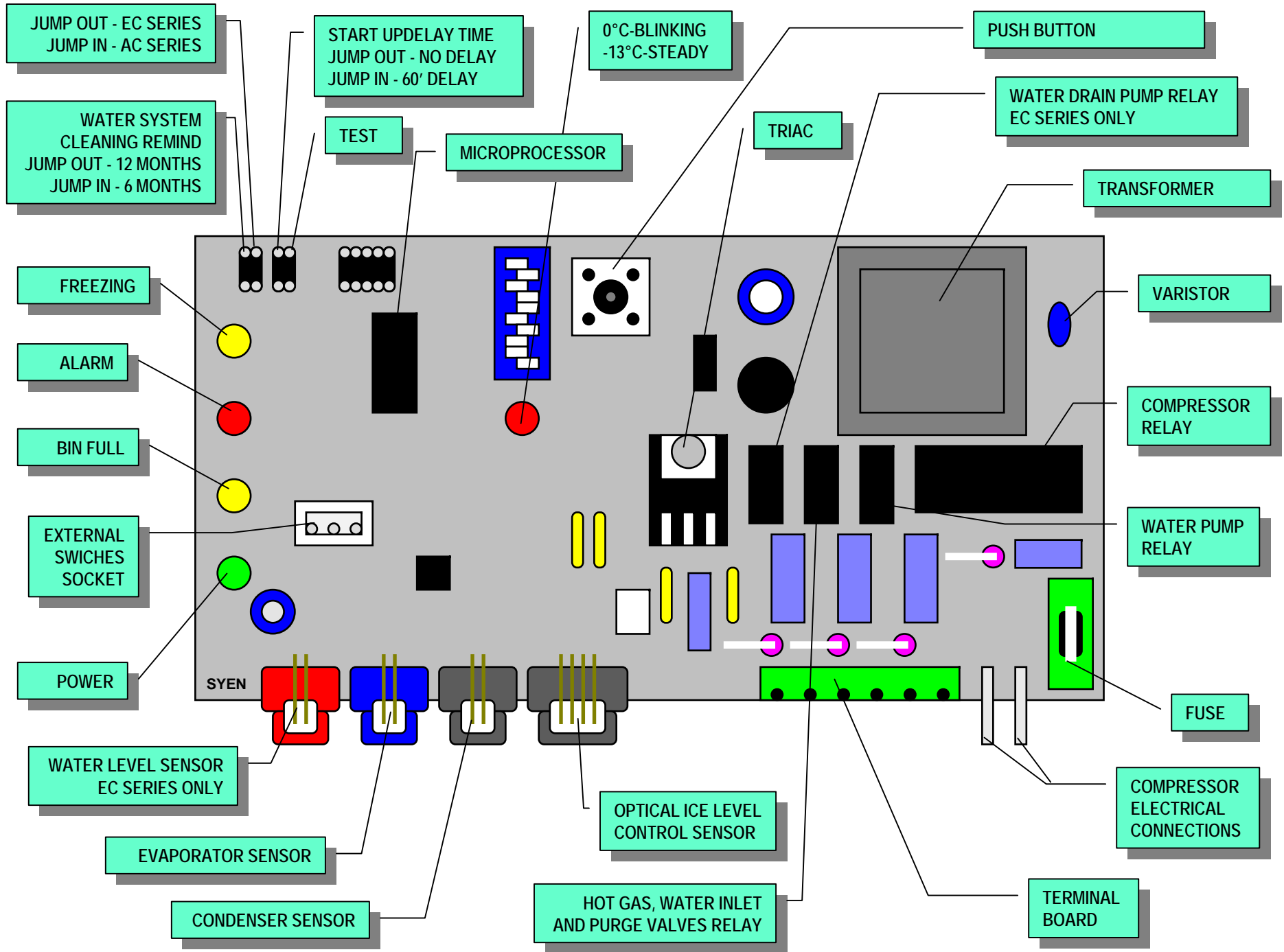

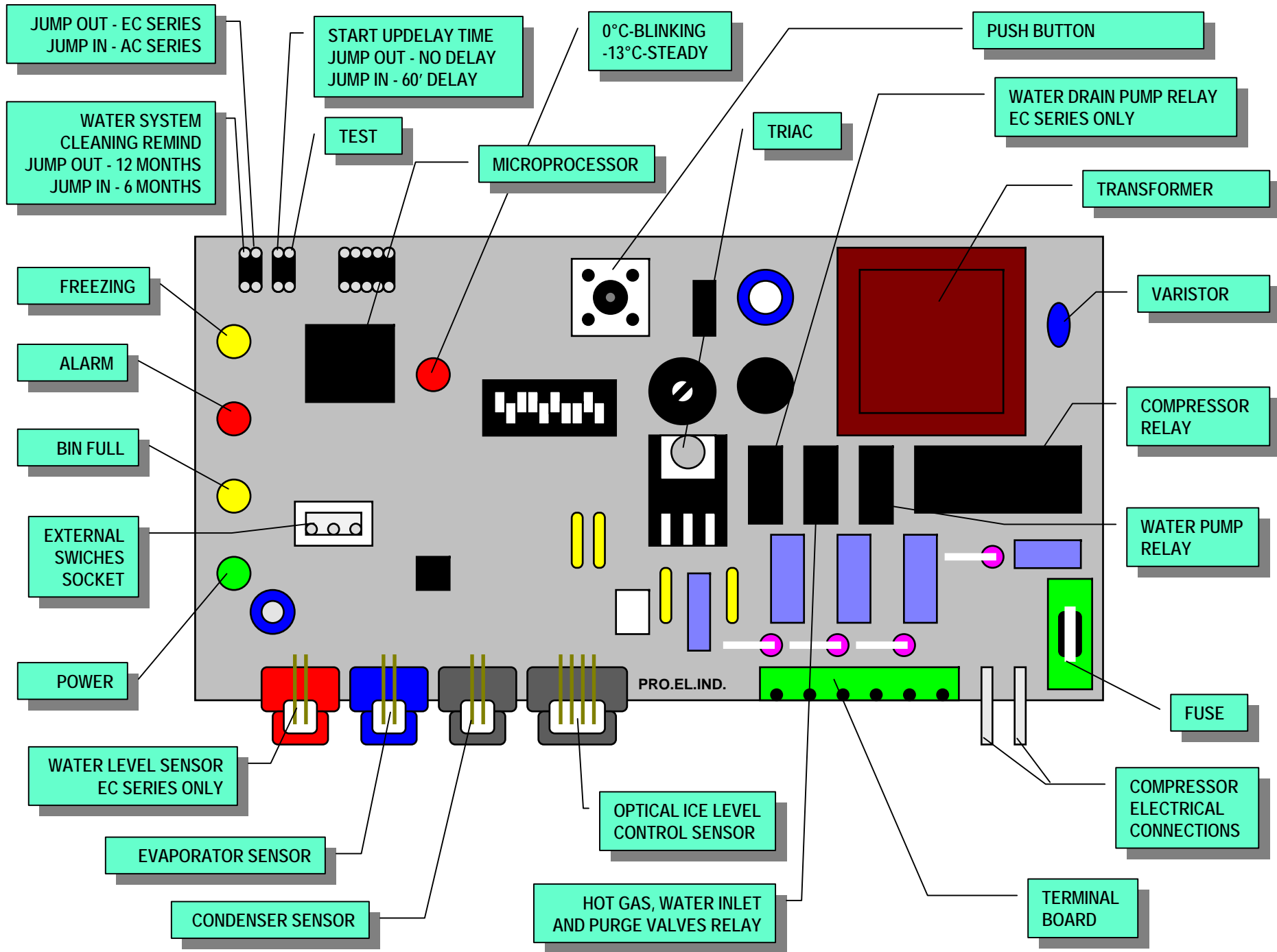



MC 8 AS/WS

ICE LEVEL OPTICAL CONTROL INSTALLATION

1. Remove screw and ice chute frame.



2. Take ice chute frame out from side panel opening area.



3. Cut plastic strap and release ice level control from its holding bracket.

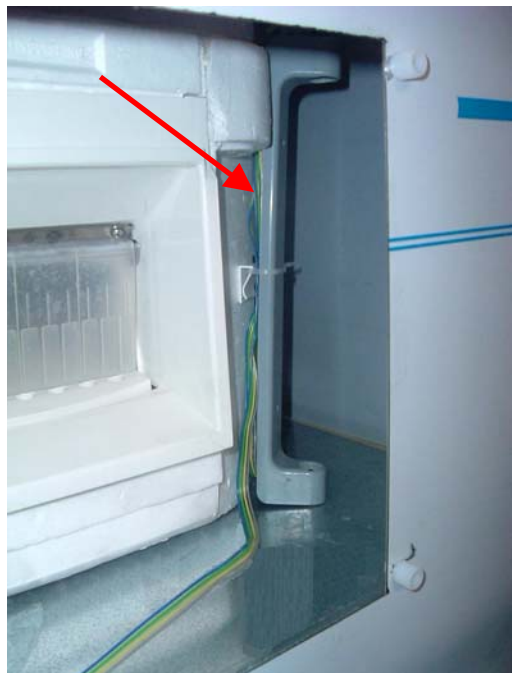

4. Install the cable protection grommet



5. Fit in cable with its protection grommet in suitable hole



.....available on the ice chute opening perimeter area



6. Check for proper installation (not too bend or pinched)

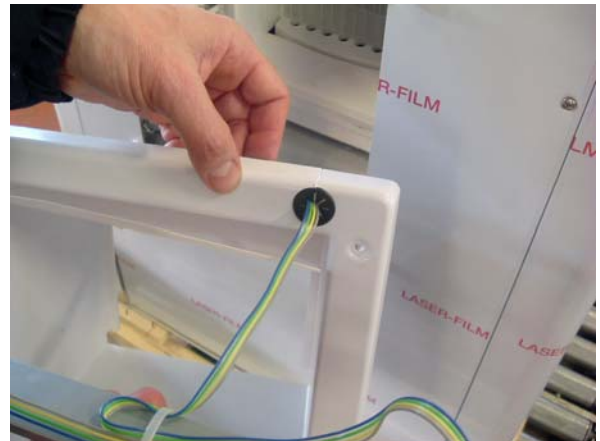

7. Install again ice chute frame



....and secure it with former removed screws



SP-08.08 – MARCH '08

AC 176 & AC 226 AS/WS

NEW PC BOARD

On the following serial numbers of models AC 176 & AC 226:

AC 176 **From s.n. 02686 to 02716**
AC 226 **From s.n. 53790 to 53819**

has been installed a new type of PC Board exactly the same one of the model MC 8 (see Service Bulletin SP-08.07).

As detailed in the Service Bulletin SP-08.07, this new PC Board, available under part nbr 620462 06, has integrated in its hardware the Cleaning/Reminder Board as well as a 16 amps relay so to enable the direct connection of the compressor to the PC Board.

The setting of the Dip Switches are exactly the same of the former PC Board used in the same models.

As detailed in the Service Bulletin SP-08.07, the calibration of the Optical Ice Level Control must be done as per follow procedure:

- Be sure that both Transmitter & Receiver of the Ice Level Control are properly clean and scale free
- Switch OFF the machine at Green Master Push Button Switch
- Push and Hold the PC Board Push Button
- Switch ON the machine at Green Master Push Button Switch
- Wait few seconds till the PC Board Leds flash once
- Release the PC Board Push Button
- Calibration is done

and the machine trips OFF at Bin Full only at the end of the Harvest/Defrost cycle.

Due to the different electrical connections, this new PC Board is NOT exchangeable with the former one used on the same models.

Attached you can find the schematic diagram of the PC Board as well as the wiring diagram of the machine.



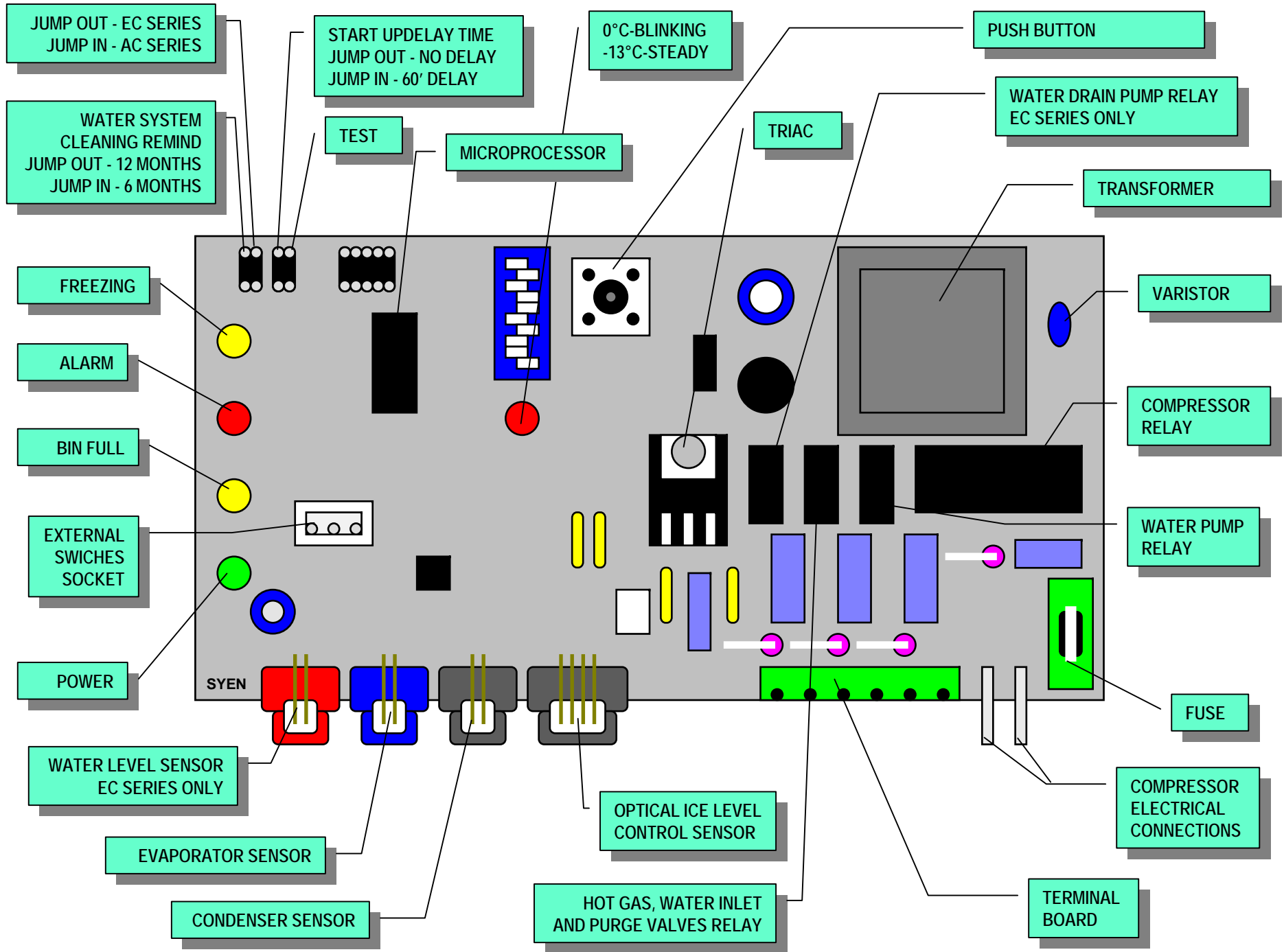

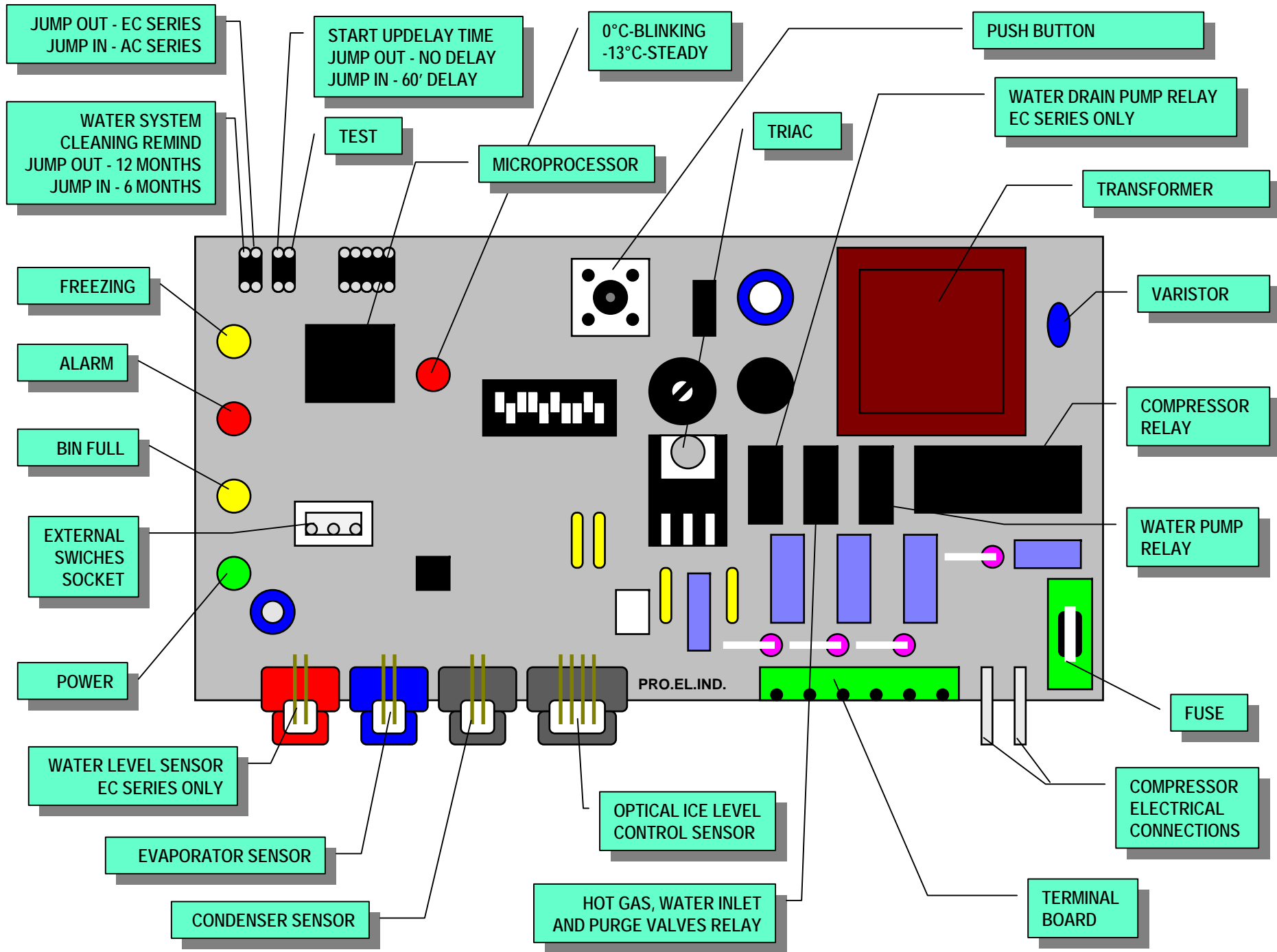

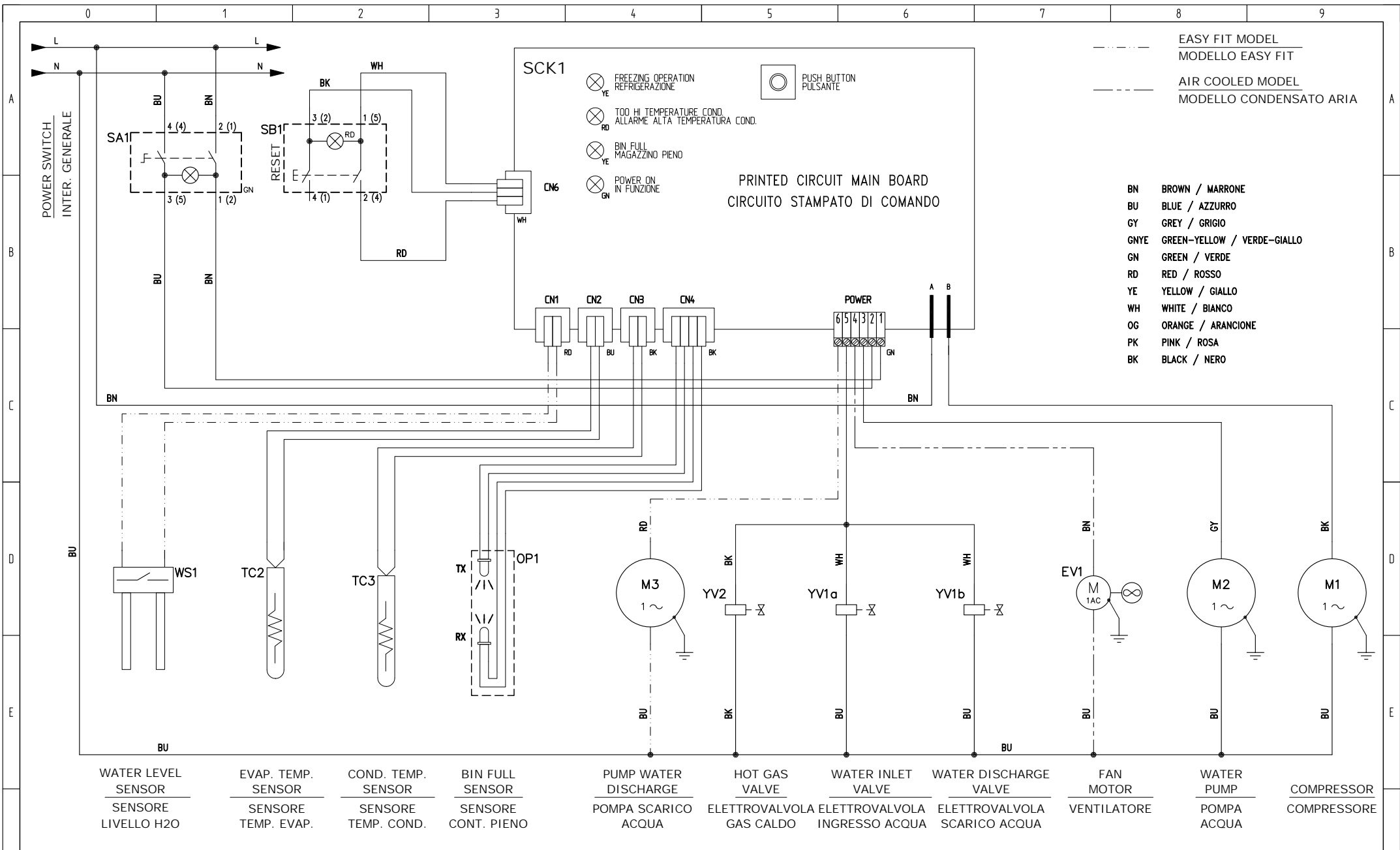







SE
R
V
I
C
E
C
O
N
T
R
O
L
L
E
T
T
E
R
S







00 - EMESSO						SCHEMA ELETTRICO ELECTRICAL WIRING DIAGRAM	AC/EC 126-176 AC/EC 206-226		230 Vac 50Hz 1ph	=	
00	04520	RG	08.11.07	DATA	08.11.07				230 Vac 60Hz 1ph	+	
				DISEGN.	R.GHIANI						
REV.	MODIFICA	SG	DATA	FIRMA	APPR.	SOST. IL :	SOST. DA :	FILE :	050572-03	00	FG. 2
0			1			08.11.07	G.ROMAGNOLI	05057230.DWG			F.T. 4

Sim.\Sym.	Sigla\Item	Funzione\Use Type	Sim.\Sym.	Sigla\Item	Funzione\Use Type	Sim.\Sym.	Sigla\Item	Funzione\Use Type
	EV1	Fan motor Ventilatore		YV2	Hot gas valve Elettrovalvola gas caldo			
	M1	Compressor Compressore		YV1a	Water inlet valve Elettrovalvola ingresso acqua			
	M2	Water pump Pompa acqua		YV1b	Water discharge valve Elettrovalvola scarico acqua			
	M3	Pump water discharge Pompa scarico acqua						
	OP1	Bin full sensor Sensore contenitore pieno						
	SA1	Power switch Interruttore generale						
	SB1	Reset push button Pulsante di reset						
	SCK1	Printed circuit main board Circuito stampato di comando						
	TC2	Evaporator temperature sensor Sensore temperatura evaporatore						
	TC3	Condenser temperature sensor Sensore temperatura condensatore						
	WS1	Water level sensor Sensore livello acqua						

00	04520	RG	08.11.07	DATA	08.11.07
				DISEGN.	R.GHIANI
				VISTO	G.ROMAGNOLI
REV.	MODIFICA	SG	DATA	FIRMA	APPR.
				G.ROMAGNOLI	

LEGENDA SIMBOLI
SIMBOLS LEGEND

AC/EC 126-176
AC/EC 206-226



230 Vac 50Hz 1ph
230 Vac 60Hz 1ph

=	
+	
00	FG. 3
	F.T. 4

SOST. IL : 08.11.07 SOST. DA : G.ROMAGNOLI FILE : 05057230.DWG

050572-03

00

FG. 3
F.T. 4

SP-08.09 – MARCH ‘08

MAR SERIES

O RINGS & GASKETS KIT

Field reports show us that in many cases, at time of replacement of the Seal Mechanism Kit due to a refrigerant leak, the Seal Mechanism (S.S and graphite rings) is still in very good conditions and can be re-fitted in the machine.

In order to reduce the repairing costs on MAR machines we made available since now a new O Rings & Gaskets repair kit available under Part Nbr 060670 00, in alternative to the Seal Mechanism Kits P/N 001028 05, consisting of the following parts:

2	O Ring	P/N	640041 10
1	O ring		640041 13
1	O ring for graphite ring		No nbr
1	O ring for S.S. Seal Mechanism ring		No nbr
1	Gasket		640076 09
1	Ring Gasket with Spring		640096 00
1	Gasket		640101 00

SEAL MECHANISM

SP-08.10 – APRIL ‘08

MF 58 - MF 68

ORIFICES/NOZZLES TXV

Starting from the following serial nbrs:

MF 58	S.N.	01559
MF 68		01542

the above models will be supplied with two different orifices/nozzles for the TXV's i.e. one of 1 mm ID and a second one of 2 mm ID.

The orifice/nozzle of 1 mm ID (Part Nbr 620427 09) **MUST** be used when the MF 58/68 is connected to a R404A centralized refrigerant system that supplies refrigerant in sub-cooled liquid state to the machine.

At contrary the 2 mm ID (Part Nbr 620427 08) **MUST** be used when the same models are connected to a system supplying refrigerant in liquid state at normal/standard temperature (35-40°C).

We would like to alert you that the use of the 2 mm ID orifice/nozzle in conjunction with refrigerant in sub-cooled liquid state supplied to the machine, can produce a very hard ice with the increasing of the mechanical load to drive the auger with the consequence of shorting a lot the life of the mechanical parts.

To avoid this type of problem all MF 58/68 will be supplied with the 1 mm ID orifice/nozzle installed inside the TXV with the 2 mm orifice/nozzle and the attached Warning Sheet packed together into a plastic bag.

**SEVERE
ICE
MELT
DOWN**

La Valvola d'Espansione Termostatica o le Valvole Termostatiche di serie sono equipaggiate con un orificio da 1 mm di diametro da utilizzare SOLO ed UNICAMENTE quando la macchina è collegata ad una centrale frigorifera a liquido SOTTORAFFREDDATO.

Qualora la macchina venisse collegata ad una centrale Standard oppure ad un gruppo condensante dedicato, è IMPERATIVO sostituire l'ugello da 1 mm della Valvola d'Espansione Termostatica con quello fornito in dotazione da 2 mm.

The TXV's is/are equipped with an orifice/nozzle of 1 mm diameter to be used ONLY when the machine is connected to a rack cooling system providing refrigerant in SUB-COOLED Liquid state.

In case of its connection to a Standard rack system or to a dedicated Condensing Unit, the original 1 mm orifice/nozzle of the TXV MUST be replaced with the 2 mm ones supplied in the machine.

Le Détendeur est équipé d'une buse de 1 mm a utiliser SEULEMENT lorsque la machine est branchée sur une centrale frigorifique a Liquide SOUS-REFROIDI'.

Quand la machine est branchée sur une centrale frigorifique Standard ou sur une groupe de condensation a distance, il est IMPERATIF de changer la buse de 1 mm du Détendeur par la buse de 2 mm fourni avec la machine.

La Válvula de Expansión Termostatica o válvula Termostatica de serie vienen equipada con un orificio de 1m/m de diámetro para utilizar **solo y únicamente** cuando la maquina es conectada a una central frigorífica con líquido subenfriado (Tewis)

En el caso de que la maquina fuese conectada a una central estándar o a una unidad condensadora independiente, es **Necesario** sustituir el cartucho de 1m/m por el de 2m/m que viene como dotación en la maquina.

SP-08.11 – APRIL '08

AC/EC 86 WS

**MODIFICATION IN HI
PRESSURE SWITCH WIRING
CONNECTION**

Starting from the AC 86 WS Serial Nbr 2247, the hi pressure switch used to energizing the coil of the water solenoid valve providing water to the water cooled condenser, it's now electrically connected in parallel to the compressor so to energize the water inlet valve coil during both freezing and harvest cycles.

Attached the new Wiring Diagram with the new electrical connection in the red square.

**S
E
R
V
I
C
E
T
E
C
H
N
I
C
A
L
S
U
P
P
O
R
T**

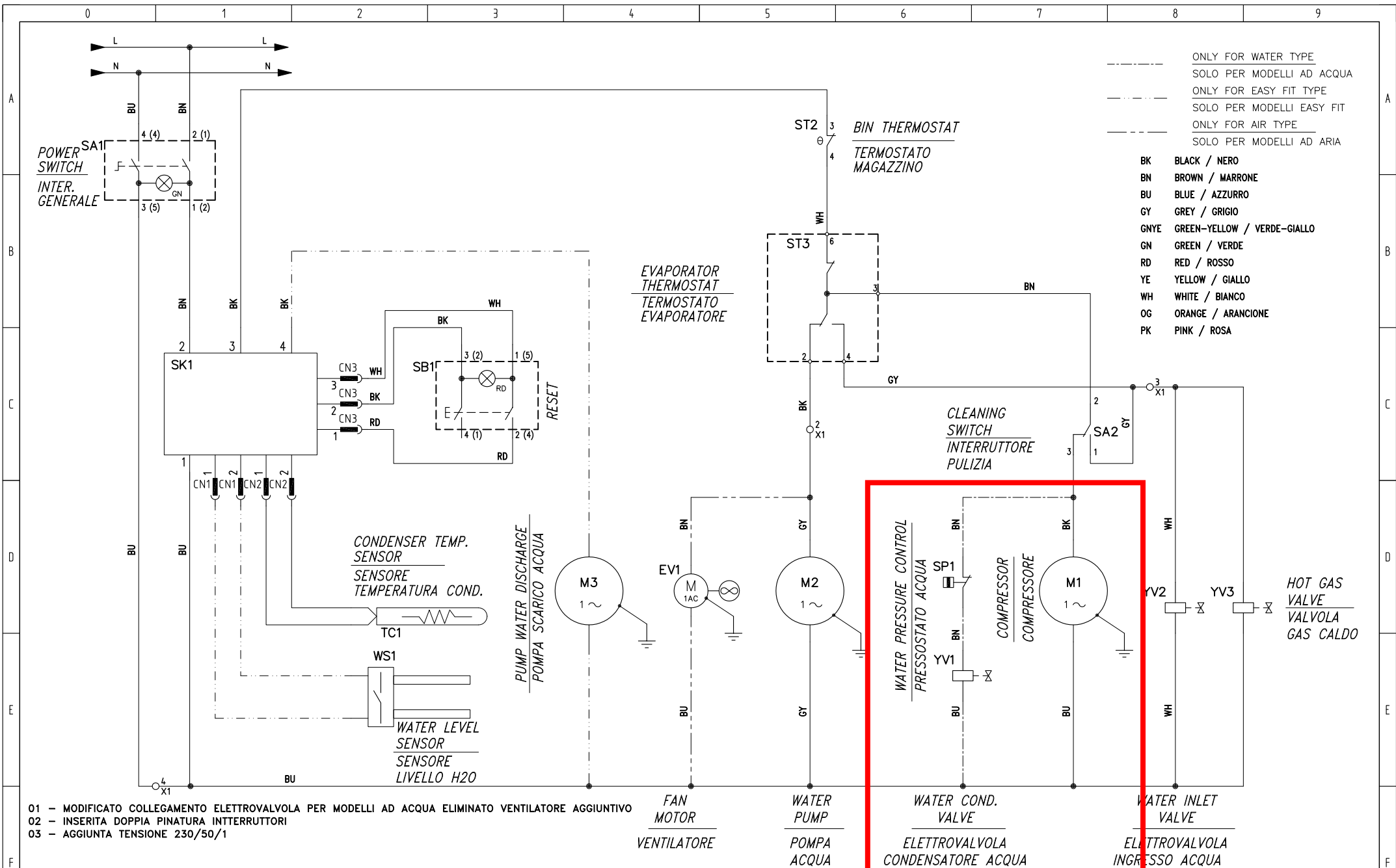

SCHEMA ELETTRICO
 ELECTRICAL WIRING DIAGRAM

AC 86











230 Vac 50 Hz 1ph
 230 Vac 60 Hz 1ph

01	04496	RG	22.05.07	DATA	27.02.07
01	04546	RG	07.09.07	DISEGN.	R.GHIANI
02	04651	RG	11.03.08	VISTO	G.ROMAGNOLI
REV.	MODIFICA	SG	DATA	FIRMA	APPR. G.ROMAGNOLI

SOST. IL : 11.03.08 SOST. DA : G.ROMAGNOLI FILE : 05053923.DWG

050539-02

03 FG. 2 F.T. 4

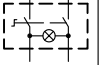
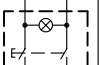
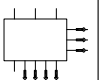
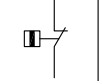
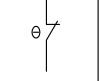
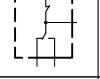
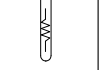
Sim.\Sym.	Sigla\Item	Funzione\Use Type	Sim.\Sym.	Sigla\Item	Funzione\Use Type	Sim.\Sym.	Sigla\Item	Funzione\Use Type
	EV1	Fan motor Ventilatore		WS1	Water level sensor Sensore livello acqua			
	M1	Compressor Compressore		YV1	Water condenser valve Elettrovalvola acqua condensatore			
	M2	Water pump Pompa acqua		YV2	Water inlet valve Elettrovalvola ingresso acqua			
	M3	Water discharge pump Pompa scarico acqua		YV3	Hot gas valve Elettrovalvola gas caldo			
	SA1	Power switch Interruttore generale						
	SB1	Reset push button Pulsante di reset						
	SK1	PWC Control board Scheda controllo PWC						
	SP1	Water pressure control Pressostato acqua						
	ST2	Bin thermostat Termostato magazzino						
	ST3	Evaporator thermostat Termostato evaporatore						
	TC1	Condenser temperature sensor Sensore temperatura condensatore						

01	04496	RG	22.05.07		DATA	27.02.07
01	04546	RG	07.09.07		DISEGN.	R.GHIANI
02	04651	RG	11.03.08		VISTO	G.ROMAGNOLI
REV.	MODIFICA	SG	DATA	FIRMA	APPR.	G.ROMAGNOLI

LEGENDA SIMBOLI
SYMBOLS LEGEND

AC 86



230 Vac 50 Hz 1ph	=	
230 Vac 60 Hz 1ph	+	
050539-02	03	FG. 3
		F.T. 4

SOST. IL :	11.03.08	SOST. DA :	G.ROMAGNOLI	FILE :	05053923.DWG
------------	----------	------------	-------------	--------	--------------

SP-08.12 – APRIL ‘08

MAR - MF SPLIT SERIES

SCOTSMAN-COS CONDENSING UNITS

SPARE PARTS LIST

Attached please find the up to dated chart showing the Part Numbers of the major components used on the following Scotsman-COS condensing units:

CONDENSING UNIT		SPLIT UNIT
SCOTSMAN MODEL NBR	COS MODEL NBR	
UCM 52	SL 1366 C8	MF 52 - MF 58
UC 071	SL 1406 C25	MAR 71
UCM 62	SM 1456 C70	MF 62 - MF 68
UC 101	SL 1456 C45	MAR 101
UC 121	SM 2456 C130	MAR 121
UC 122	SL 2406 C55	MAR 121
UC 201	SM 2456 C150	MAR 201
UC 202	SL 2406 C65	MAR 201
UCMF083	SL 2456 C85	MF 88
UC 301	UL V15HC125	MAR 301

SERVICES
ICE
EFC
B
L
J
E
N

CONDENSING UNIT COMPONENT	UCM 52 SL1366 C8	UC 051 SL 1366 C10	UC 071 SL 1406 C25	UCM 62 SM 1456 C70	UC 101 SL 1456 C45	UC 121 SM 2456 C130	UC 122 SL 2406 C55	UC 201 SM 2456 C150	UC 202 SL2406C65	UCMF083 SL2456C85	UC 301 UL V15HC125
FAN SPEED CONTROL	COS 3338002	COS 3338002	COS 3338002	COS 3338002	COS 3338002	COS 3338002	COS 3338002	COS 3338002	COS 3338002	COS 3338003	COS 3338002
FAN MOTOR	COS 3021504	COS 3021504	COS 9321570	COS 9321575	COS 9321575	COS 9321575	COS 9321570	COS 9321575	COS 9321570	COS 9321575	COS 9321558
FILTER	COS 3326195	COS 3326195	COS 3326196	COS 3326196	COS 3326196	COS 3326205	COS 3326205	COS 3326220	COS 3326220	COS 3326220	COS 3326222
SOLENOID VALVE BODY	COS 1530415	COS 1530415	COS 1530446	COS 1530446	COS 1530446	COS 1530446	COS 1530446	COS 1530460	COS 1530455	COS 1530455	COS 1530460
SOLENOID VALVE COIL	COS 1530560	COS 1530560	COS 1530560	COS 1530560	COS 1530560	COS 1530560	COS 1530560	COS 1530560	COS 1530560	COS 1530560	COS 1530560
CONDENSER COIL	COS 7840110	COS 7840110	COS 7840101	COS 7840101	COS 7840101	COS 7840101	COS 7840101	COS 7840107RI	COS 7840101	COS 7840101	COS 7840055
DOUBLE PRESSURE SWITCH	COS 3332025	COS 3332025	COS 3332025	COS 3332025	COS 3332025	COS 3332025	COS 3332025	COS 3332025	COS 3332025	COS 3332025	COS 3332025
CURRENT RELAY	*****	*****	COS 2619416	*****	COS 2619416	*****	COS 2619416	*****	*****	*****	*****
INJECTION SOLENOID VALVE	*****	*****	COS 99933796	*****	COS 99933796	*****	COS 99933796	*****	COS 99933796	COS 99933796	*****
DIFF. OIL PRESSURE SWITCH	*****	*****	*****	*****	*****	*****	*****	*****	*****	*****	COS 1732075
SAFETY RELIEF VALVE	COS 99943008	COS 99943008	COS 99943008	COS 99943008	COS 99943008	COS 99943008	COS 99943008	COS 99943008	COS 99943008	COS 99943008	COS 99943008
CRANCASE HEATER	COS 2619501	COS 2619501	COS 2619501	COS 2619501	COS 2619501	COS 2619501	COS 2619501	COS 2619502	COS 2619502	COS 2619502	COS 2619496
DISCHARGE LINE TSTAT	*****	*****	COS 2619154	COS 2619154	COS 2619154	COS 2619154	COS 2619154	*****	*****	*****	*****
KRIWAN	*****	*****	*****	*****	*****	*****	*****	COS 2619409	COS 2619409	COS 2619409	COS 2619410
COMPRESSOR	COS CAJ2464Z	COS TFH2480Z	COS ZF09	COS ZB26	COS ZF15	COS ZF18	COS ZF18	COS ZF24	COS ZF24	COS ZF33	COS 2706526
TRANSFORMER	COS 9910480	COS 9910480	COS 9910480	COS 9910480	COS 9910480	COS 9910480	COS 9910480	COS 9910480	COS 9910480	COS 9910480	COS 9910480
TIMER DELAY	COS 9910490	COS 9910490	COS 9910490	COS 9910490	COS 9910490	COS 9910490	COS 9910490	COS 9910490	COS 9910490	COS 9910490	COS 9910490
CONTACTOR	COS 99939451	COS 99939450	COS 99939450	COS 99939450	COS 99939452	COS 99939452	COS 99939452	COS 99939453	COS 99939452	COS 99939453	COS 99939453
OVERLOAD PROTECTION	COS 99939303	COS 99939352	COS 99939353	COS 99939356	COS 99939364	COS 99939358	COS 99939364	COS 99939358	COS 99939358	COS 99939360	COS 99939360

**NEW
SERIES
ICE
MACHINES**

SP-08.13 – MAY '08
AC 46-AC 56-AC 86-AC 106
WATER COOLED VERSIONS
TWO SEPARATE WATER
INLET SOLENOID VALVES

Starting from the following serial nbrs:

AC 46	S.N.	05213
AC 56		02140
AC 86		02304
AC 106		01787

the above listed models in water cooled version are now equipped with two separate Water Inlet Solenoid Valves in order to allow the connection to two different water sources (when available) as detailed on here below photo.

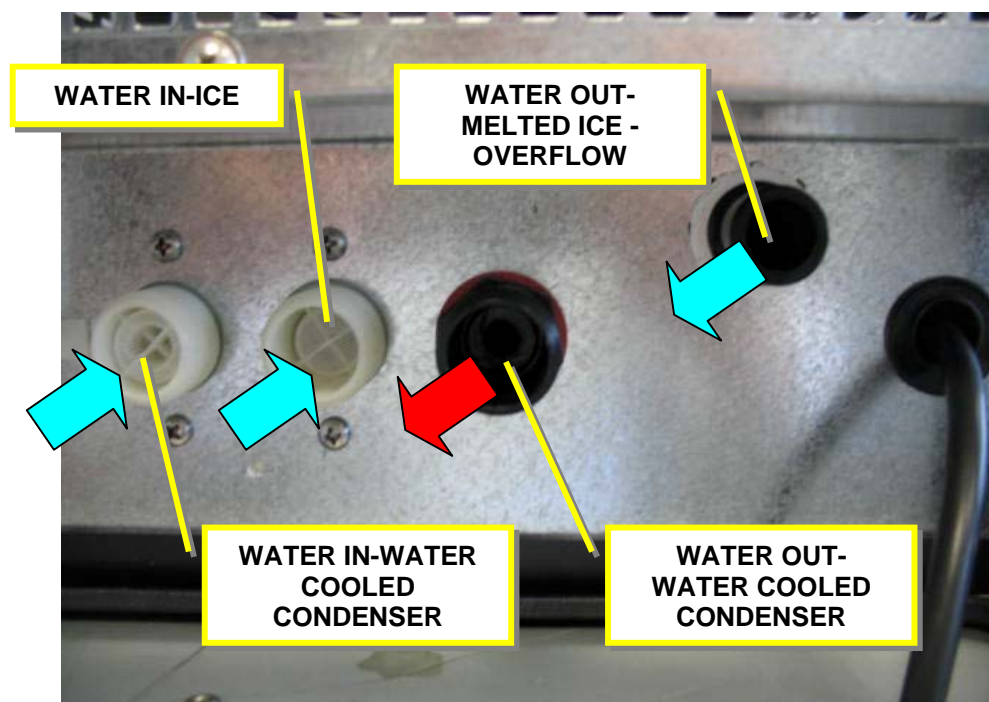

The Part Nbrs of the two new Water Inlet Solenoid Valves for the different models are:

WATER INLET SOLENOID VALVE	AC 46	AC 56	AC 86	AC 106
ICE	650105 64	650105 65	650105 66	650105 66
WATER COOLED CONDENSER	650105 74	650105 74	650105 74	650105 74

In order to facilitate the installation of the machine, when only one water source is available, together with the unit are supplied an additional water inlet hose Part Nbr 060513 00 and a "Y" fitting Part Nbr 660894 00 as shown on the photo.

This "Y" water fitting is equipped with a 3/4" female connection (to be connected to the water tap) and two 3/4" male fittings for the connection to the two Water Inlet Solenoid Valves.



**NEW
SERIES
ICE
MACHINES**

SP-08.14 – JUNE ‘08
AC 106-AC 126-AC 176
AC 206-AC 226
230/50-60/1 VERSIONS ONLY
NEW PC BOARD

Starting from the following serial nbrs:

AC 106	S.N.	01858
AC 126		01761
AC 176		02932
AC 206		00259
AC 226		53920

the above listed models are now equipped definitively with new PC Board P/N 620462 06 with the integration of the Cleaning Remind Board as detailed on the Service Bulletin SP-08.08.

All the information about the operation of this new PC Board as well as the Wiring Diagram are detailed on the Service Bulletin SP-08.08.

Service manuals as well as spare lists in Internet will be up to dated soon.

SP-08.15 – JULY '08

AF - MF SERIES

NEW PC BOARD

For field test we are putting in the field some MF 36's equipped with a new type of PC Board with the following features:

- Push button for the calibration of the Optical Ice Level Control
- 16 Amps compressor relay so to provide power directly to the compressor
- Connection to the external Switches (not yet used)

as done recently with the AC Cube Series.

In case of positive result of the field test, the modification will be extended to all our Electronic Flakers starting from the first quarter of next year.

The part number of this new PC Board is 620462 08 and it's NOT exchangeable with the former one due to the different power connectors as you can see from the bottom photo.

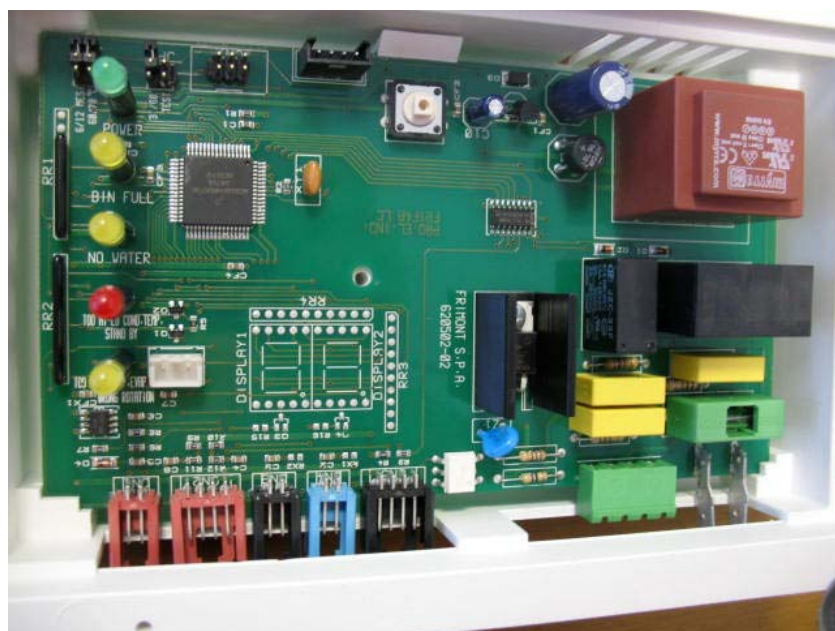

Attached the wiring diagram as well as the new PC Board layout.

NEW ICE FLAKERS

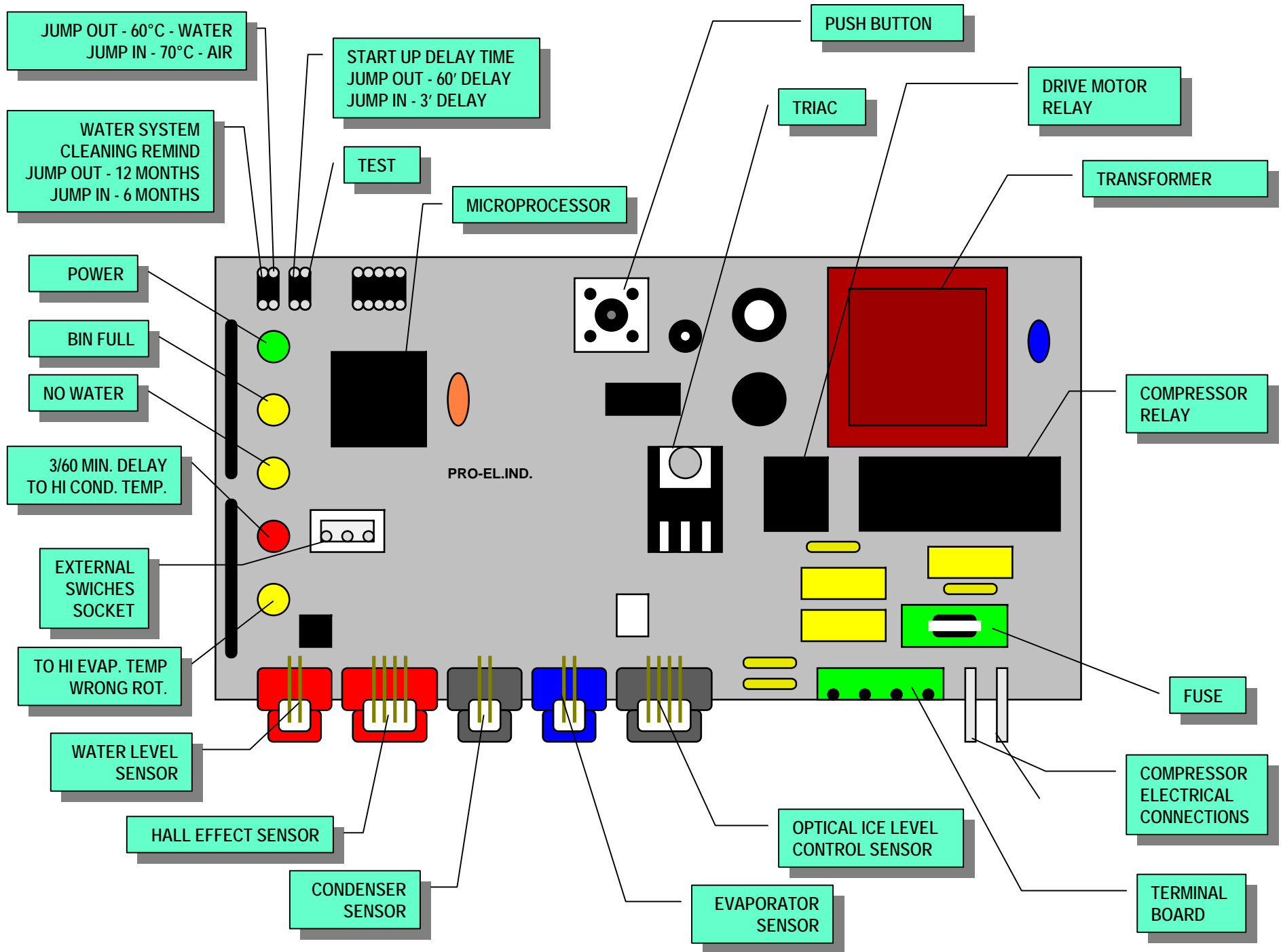

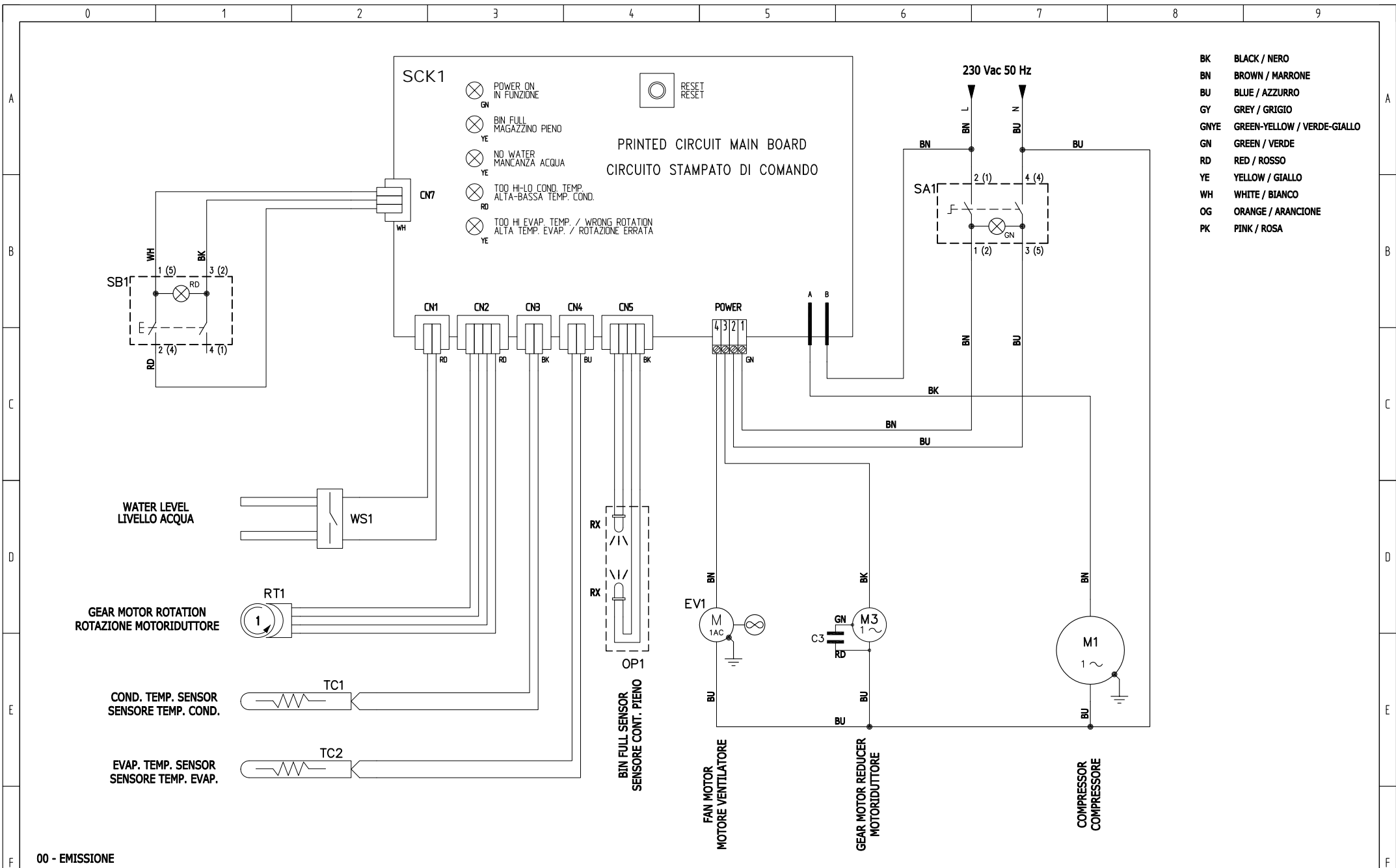

00 - EMISSIONE

00	04648	RG	09.11.07		DATA	09.11.07
					DISEGN.	R.GHIANI
					VISTO	G.ROMAGNOLI
REV.	MODIFICA	SG	DATA	FIRMA	APPR.	G.ROMAGNOLI
0			1			2

SCHEMA ELETTRICO
WIRING DIAGRAM

MF 26-36-46-56



230 Vac 50/60 Hz

050576-00

00

FG. 2
F.T. 4

Sim.\Sym.	Sigla\Item	Funzione\Use Type	Sim.\Sym.	Sigla\Item	Funzione\Use Type	Sim.\Sym.	Sigla\Item	Funzione\Use Type
	EV1	Fan motor Ventilatore						
	M1	Compressor Compressore						
	M3	Drive Motor Motoriduttore						
	OP1	BIN full sensor Sensore contenitore pieno						
	RT1	Gear motor rotation sensor Sensore rotazione motoriduttore						
	SA1	Power switch Interruttore generale						
	SB1	Reset push button Pulsante di reset						
	SCK1	Printed circuit command board Scheda elettronica di comando						
	WS1	Water level control Controllo livello acqua						
	TC1	Condenser temperature sensor Sensore temperatura condensatore						
	TC2	Evaporator temperature sensor Sensore temperatura evaporatore						

00 - EMISSIONE

00	04648	RG	09.11.07		DATA	09.11.07	LEGENDA SIMBOLI SIMBOL'S LEGEND	MF 26-36-46-56	 FRIMONT S.p.a.	230 Vac 50/60 Hz	=							
					DISEGN.	R.GHIANI					+							
					VISTO	G.ROMAGNOLI												
REV.	MODIFICA	SG	DATA	FIRMA	APPR.	G.ROMAGNOLI	SOST. IL :	09.11.07	SOST. DA :	G.ROMAGNOLI	FILE :	05057600.DWG		230 Vac 50/60 Hz		00	FG.	3
																	F.T.	4

SP-08.16 – NOV. '08

B 193 – B 393

REINFORCED BIN DOOR

Starting from the following Serial Nbrs:

B 193	S.N.	5900
B 393		8925

the plastic bin doors used on the above storage bins have been modified with a metal plate inside as shown on the attached drawing.

With this modification, on new bin doors, the two plastic hinges are now secured to a stronger inside bracket that can support much higher loads mainly when the hinge pin is partially seized.

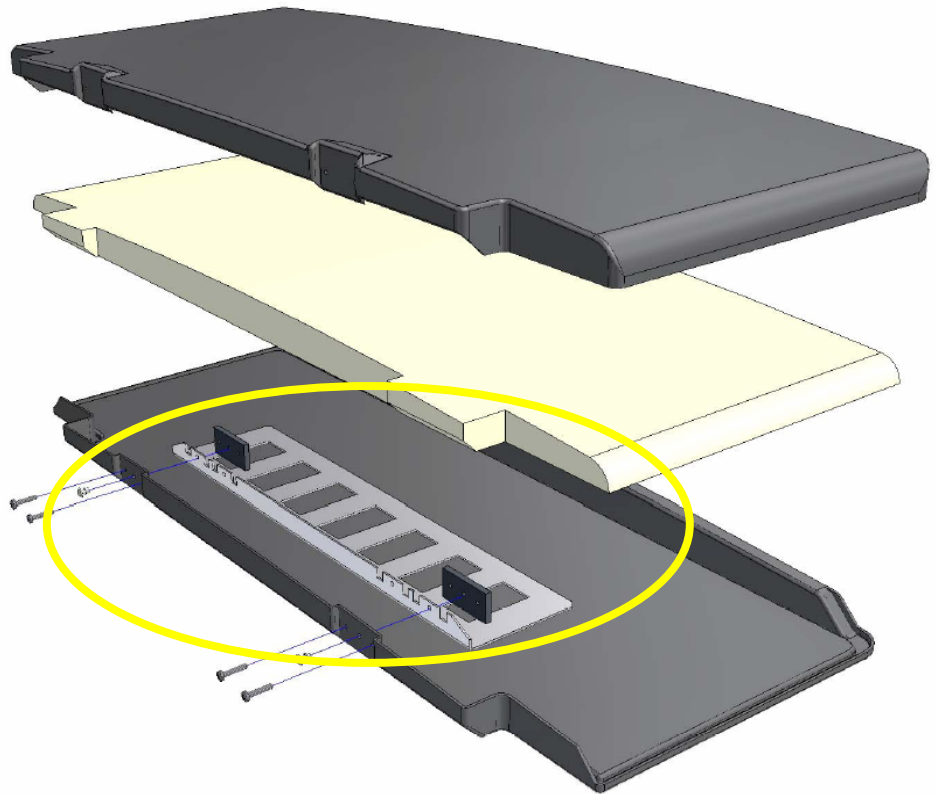

**SCOTSMAN
SERIES
MECHANICAL
EQUIPMENT**